



**UGE** Wind Turbines

**UGE 1000H**

**1.0 MW  
Wind Turbine**



### Shortest Delivery Times

The core of our business model is the availability of our products. We make every effort to provide a solution for all of our customers. We place a premium on having some of the shortest delivery times in the wind energy industry – something that our skilled manufacturers work hard to support. If you have a narrow time frame, count on UGE to deliver.

### Quality

The UGE 1000H is manufactured by an ISO9001 certified supplier to assure quality. Quality of our products is considered in everything we do.

Our dedication to the wind energy industry ensures we always deliver high quality products and customer service.

Furthermore, after we have completed our own quality tests, we have an third party complete its own tests to provide the client with further assurance. SGS ([www.sgs.com](http://www.sgs.com)) performs the pre-shipment inspection on the wind turbines with the following scope:

- \* Visual inspection
- \* Dimension control
- \* Review of test/inspection records
- \* Check of packaging

### Low Prices

Our customers receive our products at prices that are consistently among the most competitive in the wind energy industry – in addition to our already below average delivery times.

### Versatility

Our UGE 1000H turbine is designed to meet the variable wind conditions or grid specifications at your location. We can tailor our products for a wide variety of sites, from different tower heights to varying blade lengths. The integrated cooling and heating systems ensure that our turbines can operate in all types of weather. The UGE 1000H can operate in temperatures as low as -20°C and as high as 40°C. temperatures while withstanding temperatures as low as -40°C and as high as 45°C.



## Proven Technology

We provide the excellent performance by utilizing the most advanced technologies available. The UGE1000H is based on proven technology first installed in 1997 and further improved over the years. The turbines have individual pitch control to ensure they are not damaged in severe weather.



## Installation

UGE products are easy to install thanks to industry standard components. UGE has partners with international wind turbine installation companies that take pride in offering competitively priced and high quality installation capabilities. Our combined skills and experience allow us to provide for any level of installation and ongoing operation and maintenance as required.

## Functionality and Maintenance

The UGE 1000H is designed to last at least 20-years. Maintenance is quick and easy thanks to a built in crane.

## Noise Level

UGE Wind Turbines are among the quietest wind turbines in their class, measuring a sound level of 101.4dB(A) at a wind speed of 8m/s. The generator has Class H insulation to ensure noise is not an issue. The blades are engineered to minimize noise.

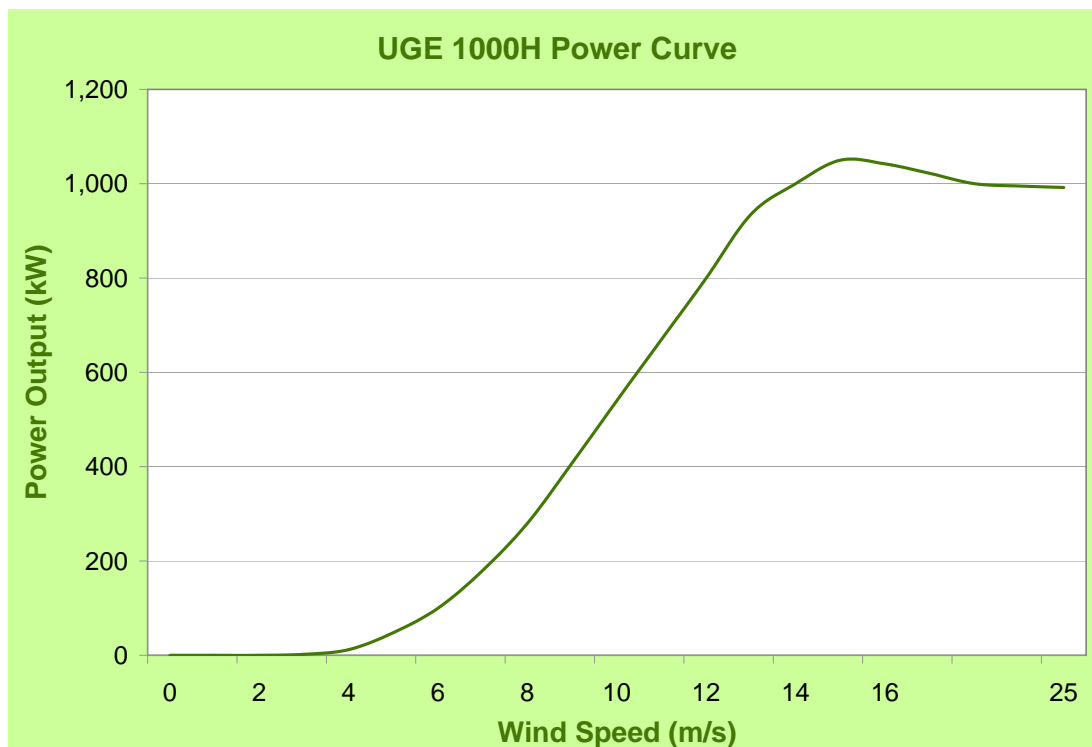



## UGE 1000H 1.0 MW Wind Turbine Specifications

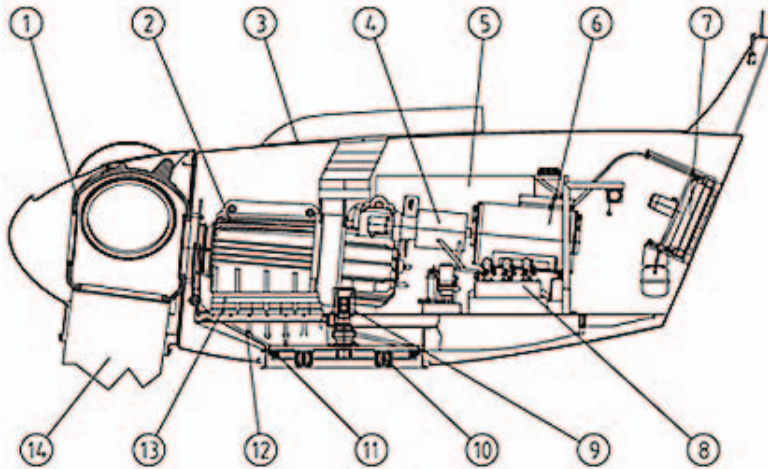

Hub	8 Pump Station
Gearbox	9 Yaw Drive
Nacelle Cover	10 Yaw Brake
Coupling	11 Yaw Bearing
Control System	12 Main Frame
Generator	13 Elastic Bearing
Cooling System	14 Blade

### Technical Parameters

Rated Power: 1000kW  
 Rated Voltage: 690V  
 Rated Frequency: 50/60 Hz  
 Operating Wind Speeds: 3.5 m/s - 25 m/s  
 Rated Wind Speed: 13.5 m/s  
 Type: IEC IIA, GL IIA  
 Number of Blades: 3  
 Rotor Diameter: 54.4m (26.4m blade length)  
 Hub Height: 70m  
 Direction of Wind Turbine: Upwind  
 Rotor Rotation Speed: 21.95 RPM  
 Power Regulating Mode: Stall  
 Primary Brake: 3-blade tip aerodynamic brake  
 Secondary Brake: Mechanical brake on highspeed shaft  
 Availability: At least 95%

### Gearbox

Design: 1-stage planetary, 2-stage bevel gear  
 Gear Ratio: 1:69.155 / 1:82.824  
 Rated Power: 1100kW  
 Lubrication: Forced w/ automatic heating and cooling

### Generator

Type: Double-coil asynchronous generator  
 Rated Power: 200/1000 kW  
 Rated Voltage: 690V  
 Rated Frequency: 50/60 Hz  
 Rated Current: 193/909A  
 Rated Rotation Speed: 1510/1516 / 1212/1818 RPM

Protection Level: IP54  
 Insulation Level: H/F  
 Lubrication Method: Automatic greasing  
 Cooling Method: Automatic water cooling

### Blade

Weight: 4.35mt per blade  
 Material: Glass-fiber reinforced  
 Tip-brake Control: Hydraulic control (auto/manual)

### Yaw System

Type: Active and automatic control  
 Yaw Bearing: Inner gear bearing  
 Yaw Speed: 0.75 degrees  
 Yaw Brake: Disc brake with dampener  
 Largest Point of Rotation: 720 degrees

### Control and Monitoring

Type: Microprocessor-based control system.  
 Monitoring: Data RMON (Remote Monitoring)

### Grid-connection

Power Factor Compensation: Capacity compensation  
 Power Factor (COSφ): 0.95~1

### Weights

Blades: 18.5mt  
 Nacelle: 40.5mt  
 Tower (68m): 88.8mt